



E.H. WACHS®

Superior Equipment. Complete Support.™

Trav-L-Cutter

Model E (Pneumatic), Model HE (Hydraulic)

Portable milling machine

The Wachs Trav-L-Cutter is a portable milling machine capable of cold cutting and beveling simultaneously on all machinable pipe materials, pipe schedules and pipe sizes from 6" up to 72" O.D. Secured by a tensioning chain, the Trav-L-Cutter drives itself around the pipe as it machines.

- Safe Cold Cutting
- Compact Design, Easy Set-Up
- Horizontal and Vertical Cutting

Fast and Accurate

Wachs high-performance cutters remove 4.8 mm (3/16") of metal while cutting, leaving the pipe end with a smooth, machined finish. The chain feed system maintains continuous out-of-round compensation while providing positive drive under all conditions for accurate cuts.

By using an optional guide track and special guide track wheels, higher accuracy can be maintained. This cutting method facilitates section removal in the field where new sections, pre-cut by the same method, can be easily dropped into place.

Operates Anywhere

In pneumatic or hydraulic driven models, the Trav-L-Cutter will operate on horizontal or vertical pipe, in the field or the shop.



All Pipe Diameter Including Tanks

Materials such as carbon steel, ductile iron, cast iron and most alloys in all pipe sizes from 6" to 72" can be cold cut and beveled simultaneously.

Hydraulic Trav-L-Cutter

Hydraulic models offer the inherent advantages of a completely sealed and self-lubricating closed loop system. The Model HE is particularly suited to field machining operations under the type of hostile conditions often found on offshore drilling rigs, pipelines and other construction work. Corrosion from constant exposure to salt water can be minimized with a stainless steel accessory package including special bearings, seals and anti-corrosive metal coatings.

Portable milling machine (Trav-L-Cutter)

Model E (Pneumatic), Model HE (Hydraulic)

Specifications

Machining Capacity:	153 to 1829 mm (6" - 72") pipe, large diameter vessels.
Cutter Drive:	Pneumatic: 2.9 kW (4 hp) governed air motor coupled with worm gearbox. Hydraulic: As above, with hydraulic motor.
Cutter Speed:	Pneumatic: Adjustable from 35 to 55 rpm for use on work-hardened alloys. Hydraulic: Adjustable from 0 to 60 rpm.
Feed:	Pneumatic: 2.9 kW (3/4 hp) air motor coupled through overload clutch, gearbox and chain reduction to final machine drive sprocket. Hydraulic: 2.9 kW (4 hp) hydraulic motor.
Feed Method:	Positive, nonslip chain drive.
Air Requirements:	100 cfm at 90 psi
Hydraulic Requirements:	15 gpm at 1500 psi
Work Speed:	3" of surface feed per minute, max. (Provides cutting the of 1 min per inch of pipe diameter). (10" pipe = 10 min.) Over 12.7 mm (1/2") wall as well as most alloys require reduced feed rate.
Clearance:	254 - 305 mm (10"-12") radial, 508 mm (20") axial.
Controls (Model E & HE):	Cutter on-off, feed on-off, with interlock to prevent machine feed unless cutter is turning, adjustable feed control. (Model HE Only) Flow control valves. Separate controls provide adjustable spindle speed and cutter speed. Forward/Reverse valve governs machine travel direction.
Weight:	Operating: 215 lbs., Shipping: 418 lbs.
Finish:	Paint.
Dimensions (LxWxH):	24" (61 cm) x 20" (51 cm) x 10.75" (28 cm).
Standard Equipment:	Operating manual and isometric parts list, Operating tools, Chain Ø 6" - 48", Connecting pins, Basic mounting chain for 6" dia. pipe, Steel storage case, Reversible feed motor, 6' whip hose w/oiler (air only)
Optional Equipment:	Additional chain for any diameter pipe, Additional cutter blades, Spray mist cooling system, Halogen-free cutter coolant, Guide track and wheels to fit all pipe sizes up to 72" for, vertical cutting multiple pass cutting or high accuracy, cutting, Long cutter spindle for use with grooving cutters, Corrosion resistant package.

Machine Operation Diagram

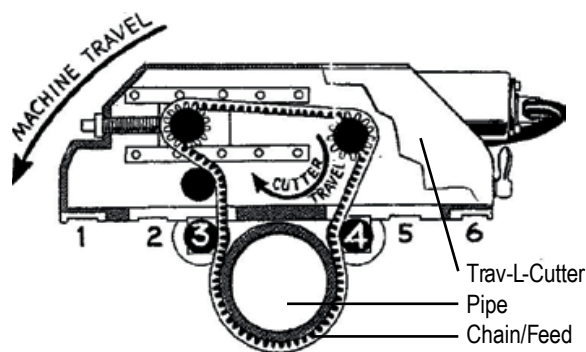

Trav-L-Cutter Slitting Blades and Bevel Cutters

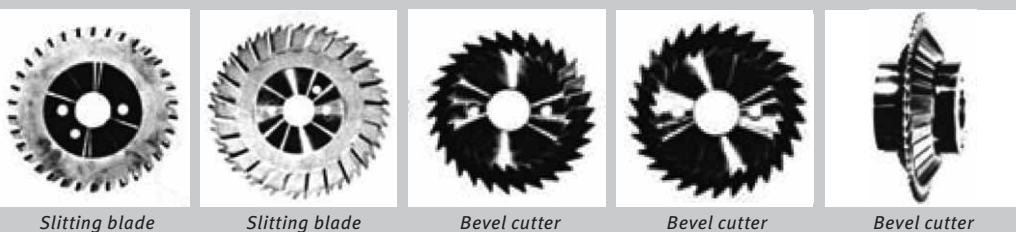

Wachs supplies a wide variety of cutting blades to meet most applications. These include slitting blades for various pipe materials and schedules, and beveling cutters for 37.5° and 30°. Most are in stock and ready for overnight shipment. Please contact your local Orbitalum Tools representative for availability.

© Orbitalum Tools GmbH (08.2010) The technical data is non-binding. It does not include any assurance of properties. Subject to change. Our general terms and conditions apply.